



US008604803B2

(12) **United States Patent**
Dooley

(10) **Patent No.:** **US 8,604,803 B2**
(45) **Date of Patent:** **Dec. 10, 2013**

(54) **SYSTEM AND METHOD FOR MONITORING TEMPERATURE INSIDE ELECTRIC MACHINES**

(75) Inventor: **Kevin Allan Dooley**, Mississauga (CA)

(73) Assignee: **Pratt & Whitney Canada Corp.**,
Longueuil (CA)

(*) Notice: Subject to any disclaimer, the term of this patent is extended or adjusted under 35 U.S.C. 154(b) by 0 days.

(21) Appl. No.: **11/419,239**

(22) Filed: **May 19, 2006**

(65) **Prior Publication Data**

US 2007/0268023 A1 Nov. 22, 2007

(51) **Int. Cl.**
G01R 31/06 (2006.01)

(52) **U.S. Cl.**
USPC **324/546; 324/765.01**

(58) **Field of Classification Search**
USPC 324/546, 525, 691, 670, 105
See application file for complete search history.

(56) **References Cited**

U.S. PATENT DOCUMENTS

2,578,455 A *	12/1951	Seely	324/703
2,912,644 A *	11/1959	Makous	324/706
2,922,943 A *	1/1960	Hermann	388/826
3,195,044 A *	7/1965	Flanagan	324/703
3,207,980 A *	9/1965	Shockroo et al.	324/706
3,210,657 A *	10/1965	Flanagan	324/706
4,083,001 A *	4/1978	Paice	324/772
4,413,325 A	11/1983	Elfner	
4,454,465 A *	6/1984	Greene	322/49
4,554,491 A *	11/1985	Plunkett	318/400.41
4,899,074 A *	2/1990	West	310/154.27
4,939,437 A *	7/1990	Frag et al.	318/473
5,153,506 A *	10/1992	Trenkler et al.	324/772

5,446,362 A	8/1995	Vanek		
6,064,172 A *	5/2000	Kuznetsov	318/716
6,262,550 B1	7/2001	Kliman et al.		
6,297,742 B1 *	10/2001	Canada et al.	340/635
6,323,658 B1 *	11/2001	Kendig et al.	324/551
6,496,782 B1	12/2002	Claus et al.		
6,949,945 B2 *	9/2005	Klein	324/772
6,965,183 B2	11/2005	Dooley		
7,242,166 B2 *	7/2007	Swahn et al.	322/28
7,262,539 B2 *	8/2007	Dooley	310/184
7,265,954 B2 *	9/2007	Hikawa et al.	361/29
2003/0034793 A1	2/2003	Lee		
2003/0111976 A1 *	6/2003	Kumar	318/783
2004/0212342 A1	10/2004	Batson		
2004/0239202 A1	12/2004	Dooley		
2009/0051311 A1 *	2/2009	Lu et al.	318/806
2010/0194329 A1 *	8/2010	Lu et al.	318/798

FOREIGN PATENT DOCUMENTS

CA	1191719	8/1985
CA	2170011 C	8/1997
EP	0726632	8/1996
JP	402080982 A *	3/1990
WO	02087050	10/2002
WO	2006056040	6/2006

OTHER PUBLICATIONS

International Search Report, PCT/CA2007/000712, Jul. 31, 2007.
EP Search Report, EP07252053; Jun. 24, 2010.

* cited by examiner

Primary Examiner — Thomas Valone

(74) *Attorney, Agent, or Firm* — Norton Rose Fulbright Canada LLP

(57) **ABSTRACT**

The electric machine comprises at least one winding made of a material having a temperature dependent resistance. The temperature of the winding is monitored using the resistance therein. Temperatures or resistances indicative of a fault can be sensed, and corrective action taken, without the need for dedicated temperature sensors.

8 Claims, 3 Drawing Sheets

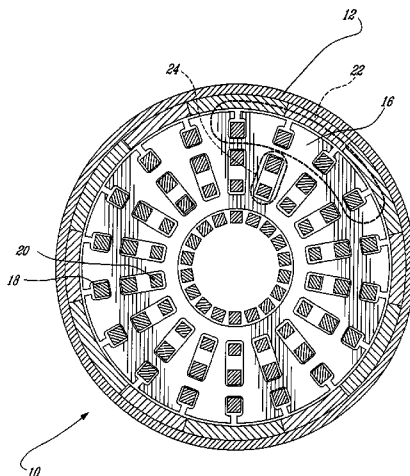

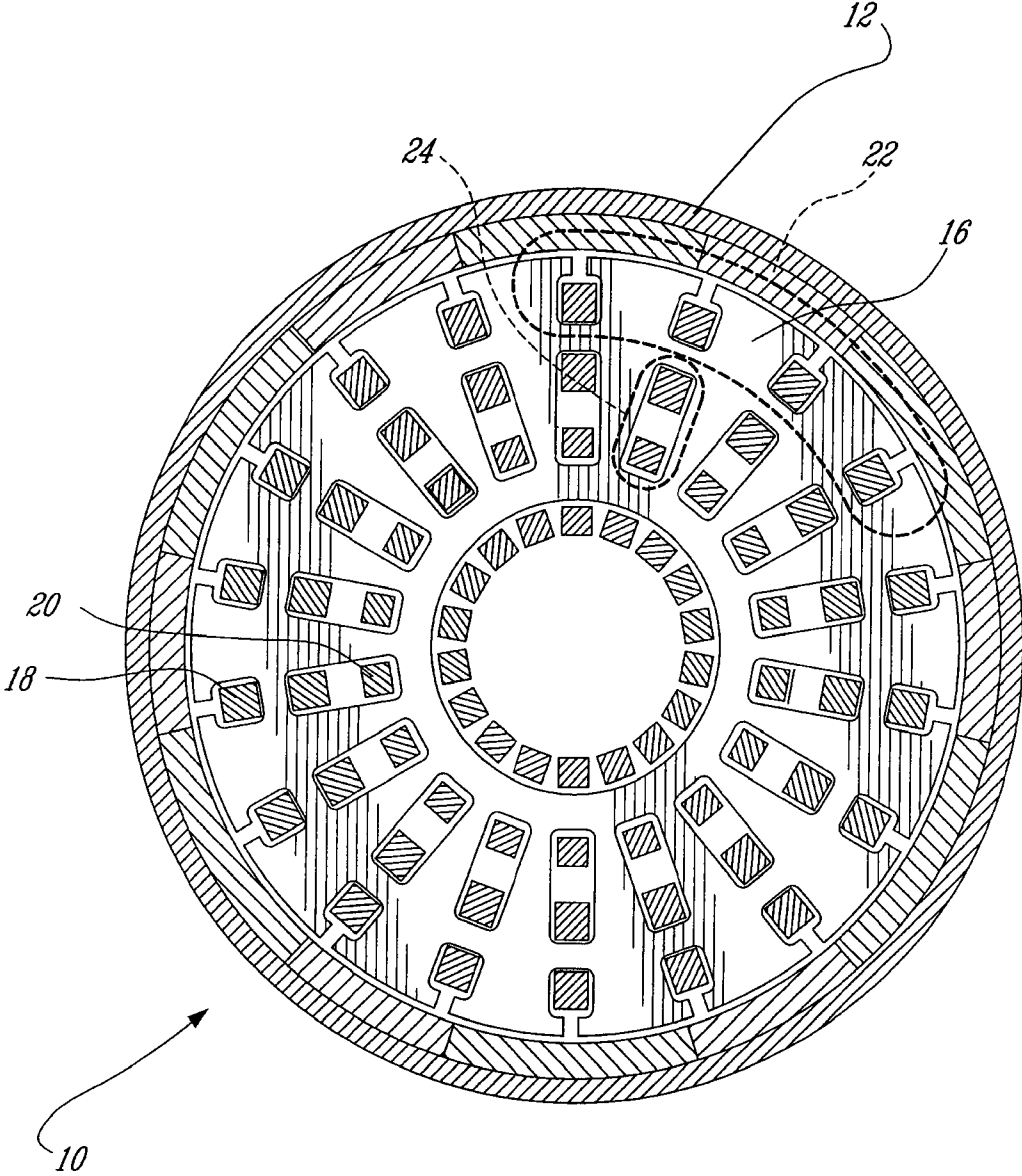

Fig. 1a

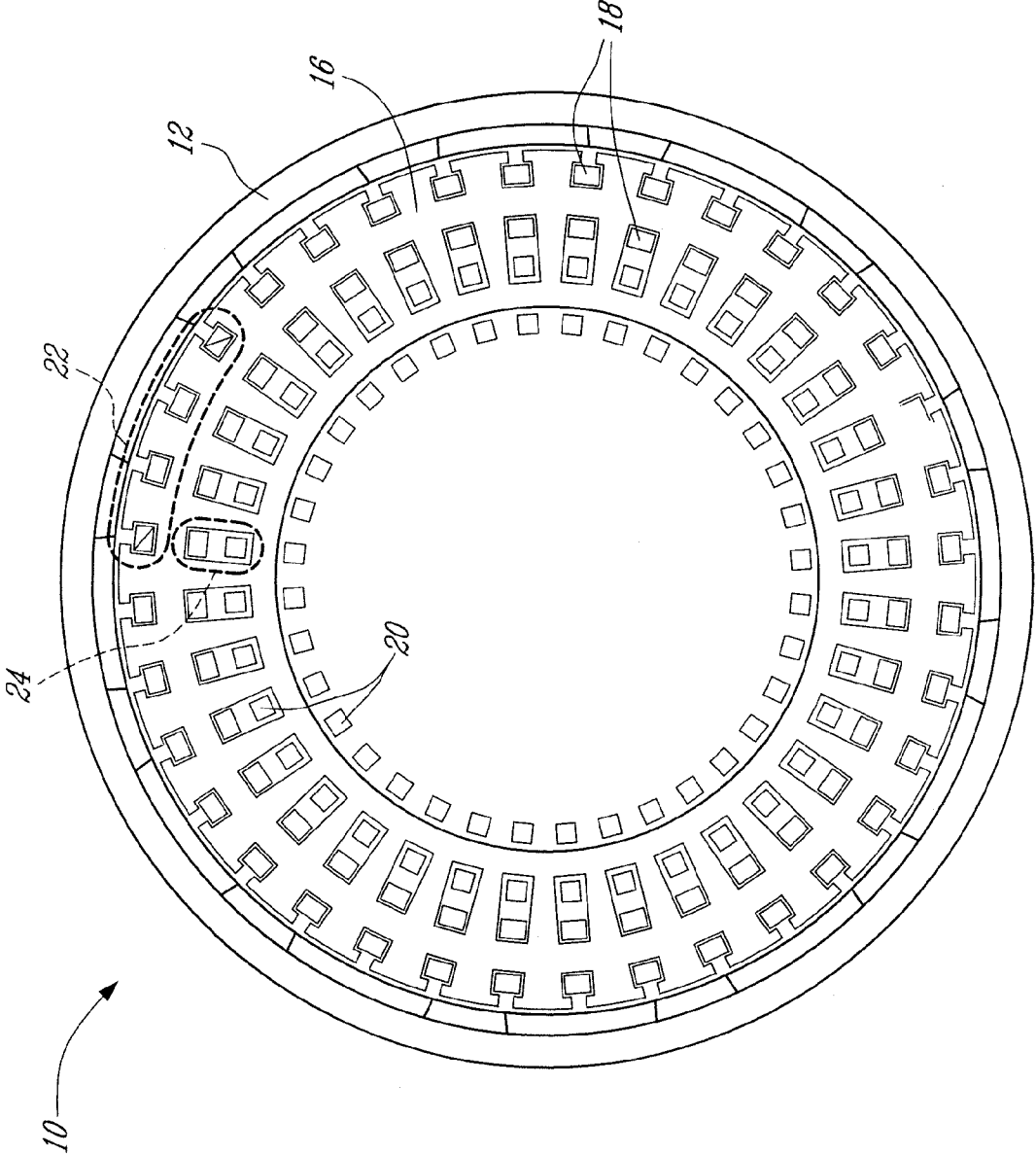

Fig. 1b

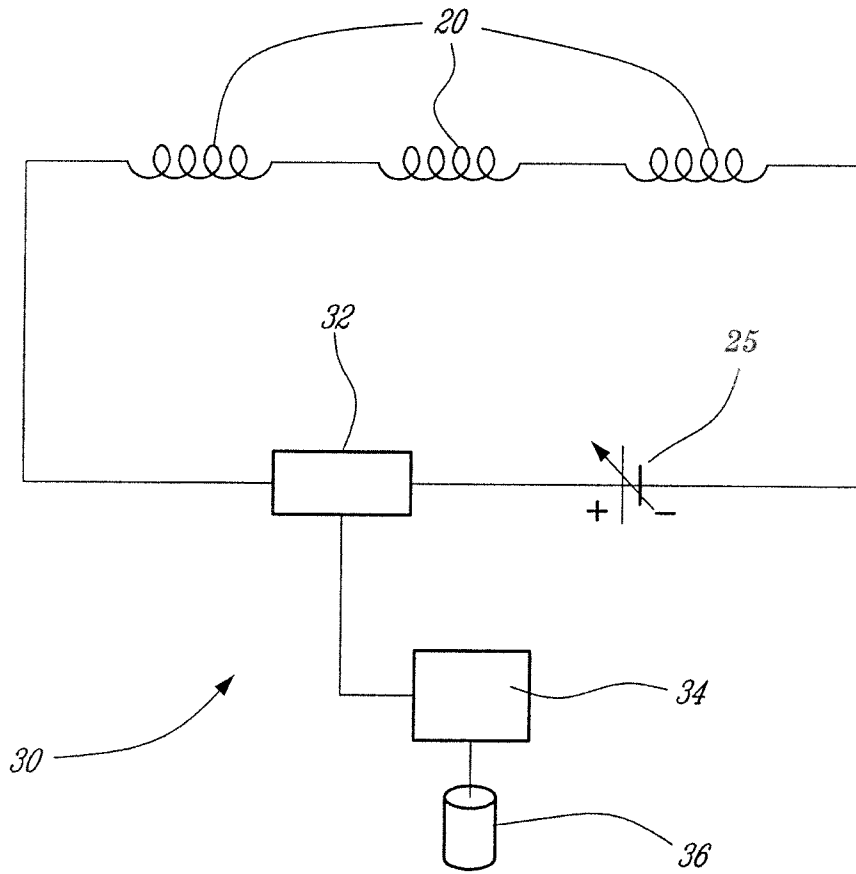

Fig. 2

SYSTEM AND METHOD FOR MONITORING TEMPERATURE INSIDE ELECTRIC MACHINES

TECHNICAL FIELD

The invention relates to temperature monitoring inside electric machines.

BACKGROUND

In the unlikely event of a turn to turn short-circuit or other electrical fault inside an electric machine such as a motor or generator, the temperature at the faulted winding can become significantly elevated and thereby pose a risk to the continued operation of the machine. However, no other symptoms may be evident initially, until the insulation of the winding deteriorates to a significant level, after which a more serious thermal condition may result. Providing temperature sensors to sense a high temperature within a faulted winding can detect a fault, however, such arrangement adds complexity to the electric machine. Room for improvement exists.

SUMMARY

In one aspect, the present invention provides a method for monitoring temperature of at least one winding of an electric machine, the winding having a temperature dependant resistance, the method comprising: determining a resistance of the winding while in operation; and determining a winding temperature of the winding using the resistance therein.

In another aspect, the invention provides a system for monitoring temperature of at least one winding of an electric machine, each winding having an electrical resistance which changes with temperature, the system comprising: a monitor adapted to determine a value indicative of the instantaneous resistance in at least a portion of the at least one winding; and a processor adapted to calculate an instantaneous temperature based on the resistance, and determine the presence of a fault condition based on the temperature.

In a further aspect, there is provided an electric generator system comprising a generator having a permanent magnet rotor and a stator, the stator having at least one output winding connected to a generator load and at least one control winding, the windings disposed in stator slots, the stator defining a first magnetic circuit passing through the stator around a portion of the at least one output winding, the stator defining a second magnetic circuit passing through the stator around another portion of the at least one output winding and a portion of the at least one control winding, the first and second magnetic circuits remote from one another, the at least one control winding having an electrical resistance which varies with temperature; a current source connected to the at least one control winding adapted to provide variable DC current thereto, the source and the at least one control winding providing a control circuit; and a fault detection apparatus connected to the control circuit, the fault detection apparatus adapted to determine an electrical resistance of the at least one control winding and detect a fault therefrom.

BRIEF DESCRIPTION OF THE FIGURES

Reference will now be made to the accompanying figures, in which:

FIGS. 1a and 1b are a schematic cross-sectional views of examples of an electric machine suitable for use with the present invention; and

FIG. 2 is a block diagram showing an example of a system for monitoring the temperature of an electric machine.

DETAILED DESCRIPTION

FIG. 1a shows an example of an electric machine 10 of the general type described in applicant's U.S. Pat. No. 6,965,183, while FIG. 1b shows an example of an electric machine of the general type described in applicant's U.S. Pat. No. 7,262,539, both incorporated herein by reference. In both cases, the machine 10 can be used as a motor and/or a generator, and includes a rotor 12 (a permanent magnet rotor is shown in the figures) and a stator 16 having a plurality of primary windings 18 and secondary windings 20. The primary windings 18 generate output power in response to rotor rotation (generator) or create a rotating electromagnetic field to cause rotor rotation (motor). Primary windings 18 and secondary windings 20 are electrically isolated from one another. The secondary windings 20, in this example, are wrapped around a portion of the stator preferably multiple times, such as 25 times in each respective slot, as described in U.S. Pat. No. 7,262,539. Thus, each slot provides a sort of coil, the coils are connected in series around the portion of the stator serviced by the secondary winding. The secondary windings 20 are used to control the operation of the electric machine 10 through affecting primary windings 18, as described in the incorporated references. A rotor magnetic circuit 22 and a secondary magnetic circuit 24 are defined in the stator 16 for directing magnetic flux within the machine 10. Secondary windings 20 are preferably aluminium, copper or other material (whether pure, alloy or composite, etc.) in which material temperature affects the material's electrical resistivity.

FIG. 2 schematically illustrates an example of a system 30 for monitoring the temperature of one or more secondary windings 20 (three windings connected in series are shown in this example), while machine 10 is in operation without the need for dedicated temperature sensors or thermocouples. The system 30 comprises a monitoring device 32 connected in series with the windings of interest, in this case secondary windings 20. If there is more than one set of target windings in the machine 10, more than one monitoring unit 32 per machine may be provided.

The secondary windings 20 of machine 10 actually comprise a plurality of windings that are connected in series, and are also connected to a voltage source, in this case preferably a variable DC source 25. For example, as described in the incorporated reference U.S. Pat. No. 7,262,539, input DC may be provided by source 25 to saturate a portion of the stator 16 to thereby allow regulation of the output current of the primary stator windings 18 over a range of rotor speeds and electrical loads. The monitoring device 32 is adapted to determine parameters used to determine winding resistivity, such as voltage and current in the secondary windings 20.

Once obtained, the parameters are sent to a processor 34, which may or may not be integrated within the monitoring device 32, as desired. The processor 34 calculates the instantaneous winding resistance based on the provided parameters. In this case, the voltage and the current data is used to obtain the resistance simply using Ohm's law (i.e. $V=IR$). Other parameters and other techniques may be used. Whatever the technique used, by monitoring relevant operational parameters of the target winding, such as voltage and current flow through the control windings 20, one can monitor resistance. When the target windings are made of a temperature dependent material, for instance aluminium or copper, the temperature of the windings may be determined from the resistance. This could be done, for instance, using a suitable algorithm in

3

the processor 34, or by using a look-up table stored in a memory 36, or in any other suitable manner.

In use, in the event of a short-circuit causing the local temperature in the faulty winding to increase, thereby changing its resistance, the average resistance of the winding or windings will correspondingly increase, and this will be detected by the system. Comparison of a resistance change against a selected threshold will indicate the existence of a fault or other condition requiring attention. Upon detection of a resistance change indicative of a fault condition, a suitable corrective action can be taken, such as to notify a machine operator, to notify a machine controller for automatic machine shutdown or other fault mitigation, and/or to notify a machine maintenance monitoring system for logging an appropriate maintenance action, to name just a few. As well, gradual changes in resistance may be monitored over time for an overall indication of a health trend of the machine, and parameters indicating that a presently operational machine may soon become subject to a fault can be sensed, the fault predicted and an appropriate corrective action taken in advance of any occurrence of the fault.

As can be appreciated, the present system and method can be used to monitor the temperature inside the electric machine without a need of dedicated temperature sensors therein. The system can also be used as an additional monitoring system, if required, when dedicated temperature sensors are provided.

The above description is meant to be exemplary only, and one skilled in the art will recognize that other changes may also be made to the embodiments described without departing from the scope of the invention disclosed as defined by the appended claims. For instance, the present invention is not limited for use with the machine as shown in FIGS. 1 and 2, and it may be used with other suitable machine designs as well. The type and nature of the windings monitored may be any suitable, and the material of which the target windings are made may likewise be any suitable. The monitoring of the winding's parameters may be done in any suitable manner, and any suitable technique may be used to determine the winding's resistance. Other changes from the described embodiment may be apparent to the skilled reader, and are not meant to be excluded from the scope of the appended claims merely because all possible variants and changes have not been exhaustively described.

What is claimed is:

1. A method for monitoring an electric machine comprising a rotor and a stator, the stator having a primary set of stator windings configured to provide an electrical output of the machine and a secondary set of series-connected stator windings electrically isolated from the primary set of stator windings, the secondary set of series-connected stator windings being distributed around at least a portion of the stator and configured to control the electrical output of the primary set of stator windings, the method comprising:

4

operating the machine by rotating the rotor to generate the electrical output with the primary set of stator windings and providing a DC input current to the secondary set of series-connected stator windings to control the electrical output of the primary set of stator windings;

determining a resistance across the secondary set of series-connected stator windings while the machine is in operation, the resistance determined from the DC current in the secondary set of series-connected stator windings and a DC voltage drop across the secondary set of series-connected stator windings;

estimating a temperature of the secondary set of series-connected stator windings using the resistance determined; and

determining the presence of a machine fault condition by comparing the estimated temperature against a selected threshold condition indicative of a fault.

2. The method of claim 1 further comprising the step of taking a corrective action based on a determination that a fault is present.

3. The method of claim 1 further comprising using the estimated temperature and the comparison information to determine a suitable corrective action.

4. The method of claim 1, further comprising the step of obtaining trend information over time by storing the estimated temperature over time.

5. The method of claim 4 further comprising using the trend information to predict a future maintenance event.

6. The method of claim 4 further comprising using the estimated temperature and the comparison information to suggest a possible suitable maintenance action.

7. A system for monitoring an electric machine, the system comprising:

a rotor, a stator, a primary set of stator windings disposed in the stator and configured to conduct electricity induced by rotor rotation, and a plurality of secondary series-connected control windings disposed in the stator and electrically isolated from the primary set of stator windings, the secondary series-connected control windings being configured to permit regulation of said electricity in the primary stator windings upon the application of DC current to the secondary series-connected control windings;

a monitor adapted for monitoring a DC voltage across the secondary series-connected control windings and a DC current across the secondary series-connected control windings; and

a processor adapted to calculate an instantaneous estimated temperature of the secondary series-connected control windings based on the instantaneous DC voltage and DC current, and to determine the presence of a fault condition based on the instantaneous estimated temperature.

8. The method of claim 1 wherein the fault is a short circuit in the secondary set of stator windings.

* * * * *