



US006672847B2

(12) **United States Patent**
Dooley

(10) **Patent No.:** **US 6,672,847 B2**
(45) **Date of Patent:** **Jan. 6, 2004**

(54) **STANDING WAVE EXCITATION CAVITY FLUID PUMP**

(75) Inventor: **Kevin Allan Dooley**, Mississauga (CA)

(73) Assignee: **Pratt & Whitney Canada Corp.**, Quebec (CA)

(*) Notice: Subject to any disclaimer, the term of this patent is extended or adjusted under 35 U.S.C. 154(b) by 0 days.

(21) Appl. No.: **10/033,767**

(22) Filed: **Dec. 27, 2001**

(65) **Prior Publication Data**

US 2003/0124006 A1 Jul. 3, 2003

(51) **Int. Cl.⁷** **F04B 45/067**

(52) **U.S. Cl.** **417/412; 417/394**

(58) **Field of Search** **417/322, 394, 417/412, 383, 413.1**

(56) **References Cited**

U.S. PATENT DOCUMENTS

- 2,888,877 A * 6/1959 Shellman et al. 417/413.1
- 3,150,592 A * 9/1964 Stec 417/322
- 3,173,372 A * 3/1965 Baldwin 417/394

- 3,743,446 A 7/1973 Mandroian
- 4,488,854 A 12/1984 Miller
- 5,020,977 A 6/1991 Lucas
- 5,267,836 A 12/1993 Culp
- 5,769,608 A 6/1998 Seale
- 6,079,214 A 6/2000 Bishop
- 6,234,765 B1 5/2001 Deak

FOREIGN PATENT DOCUMENTS

- DE 2516165 10/1976
- DE 19539020 4/1997

* cited by examiner

Primary Examiner—Michael Koczo

(74) *Attorney, Agent, or Firm*—Bachman & LaPointe, P.C.; Jeffrey W. Astle; Todd A. Bailey

(57) **ABSTRACT**

A pump includes an outer body; and a wall within said outer body. The outer body and the wall define a pumping cavity and an excitation cavity within the outer body. An excitable medium is contained within the excitation cavity. An excitation source is coupled to said excitable medium. This excitation source is operable to excite the excitable medium and create a standing wave therein. The standing wave acts through the wall to pump said fluid through said pumping cavity. Advantageously, the excitable medium is isolated from the pumped fluid by the wall.

27 Claims, 8 Drawing Sheets

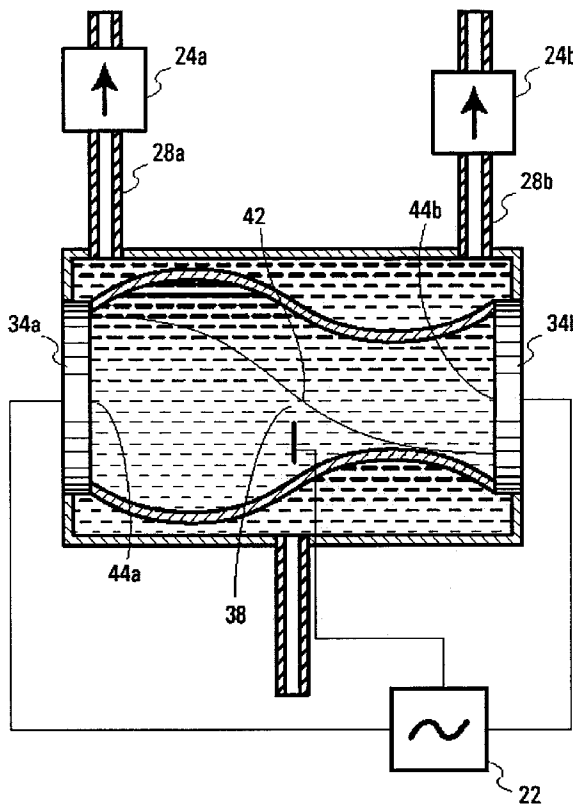

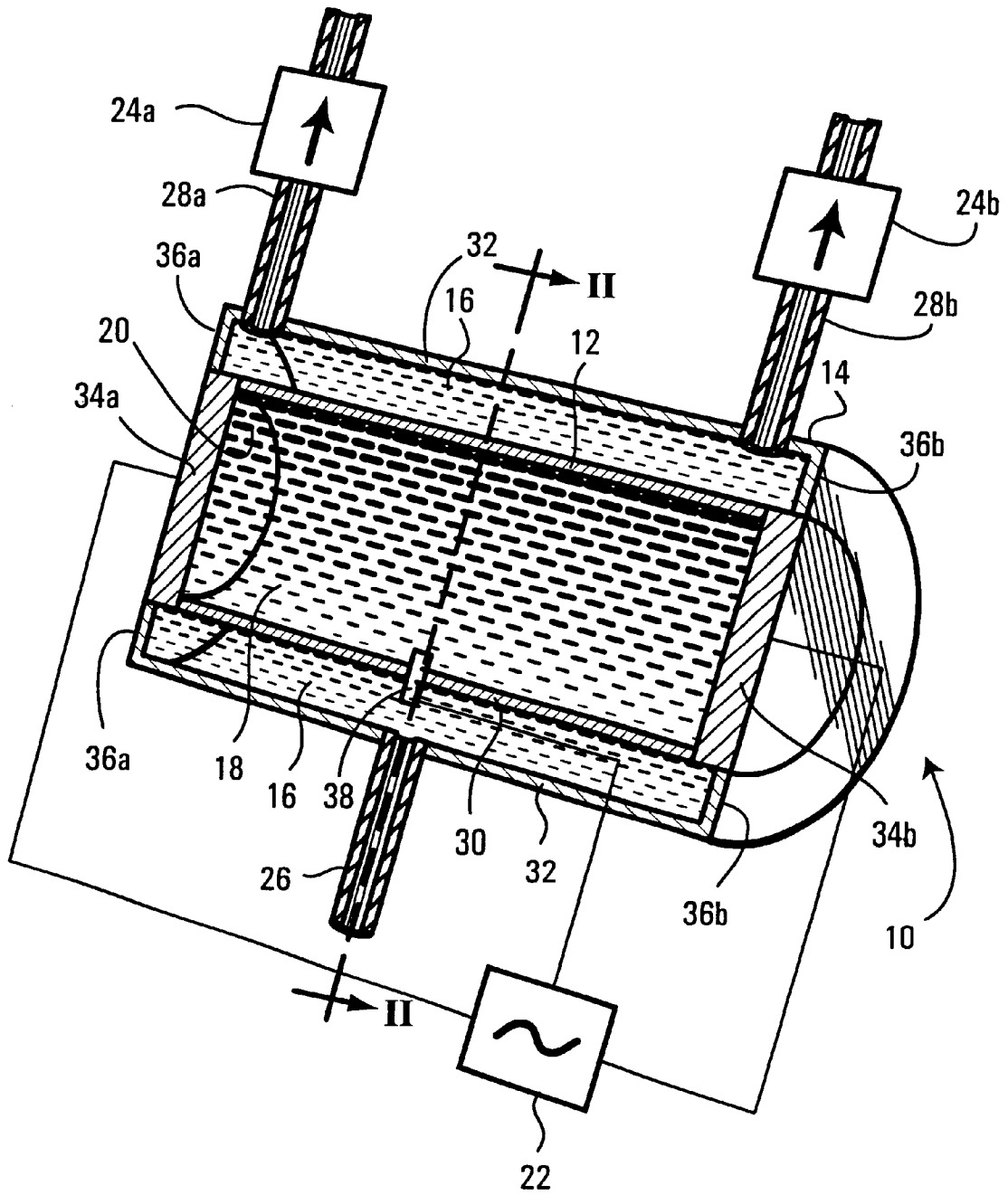

FIG. 1

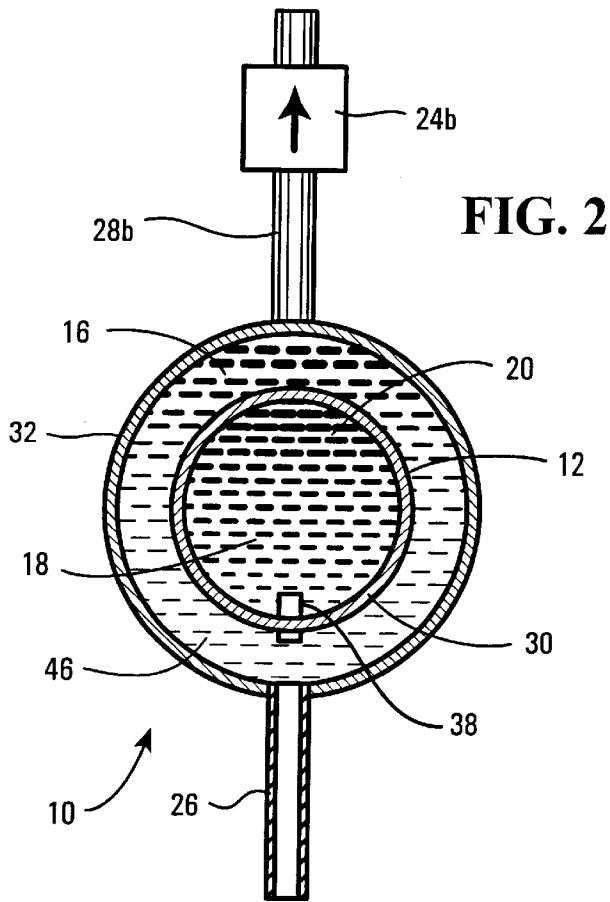

FIG. 2

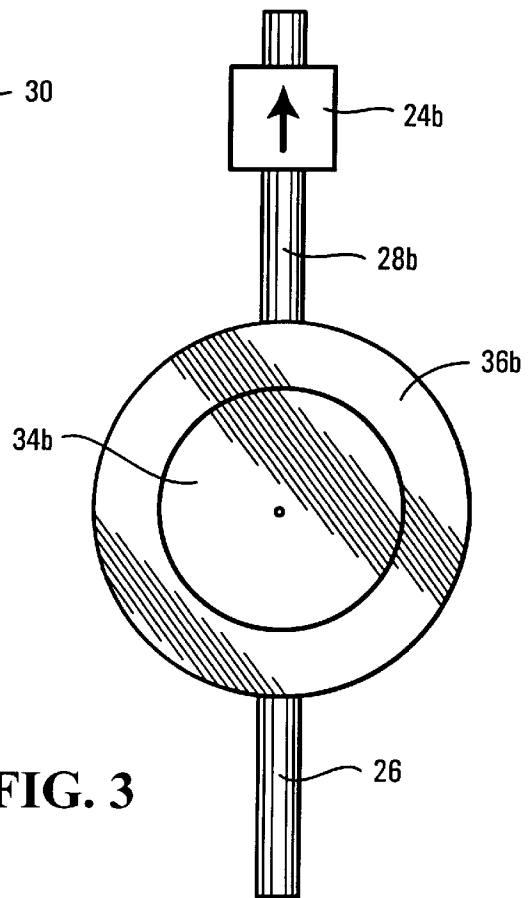

FIG. 3

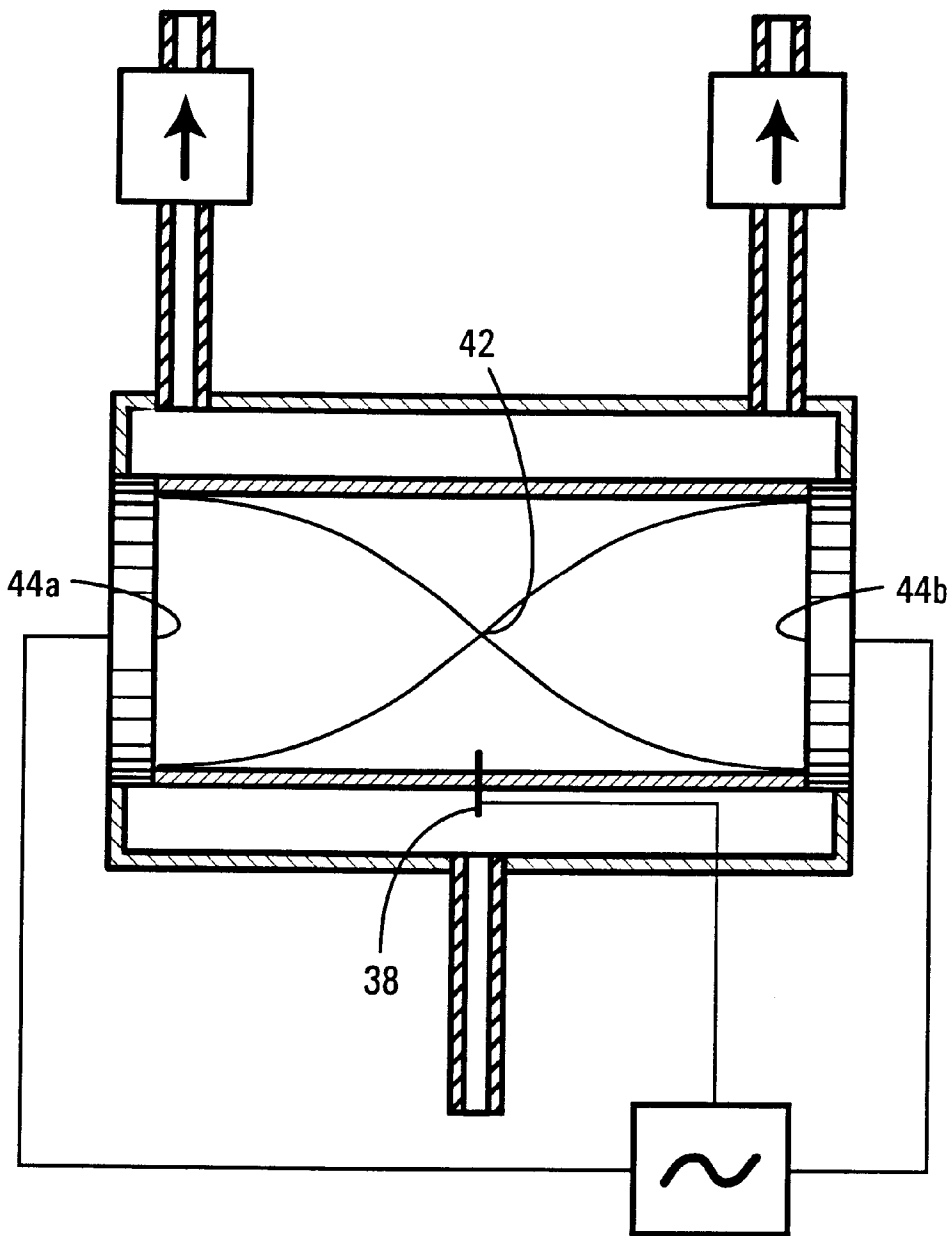

FIG. 4

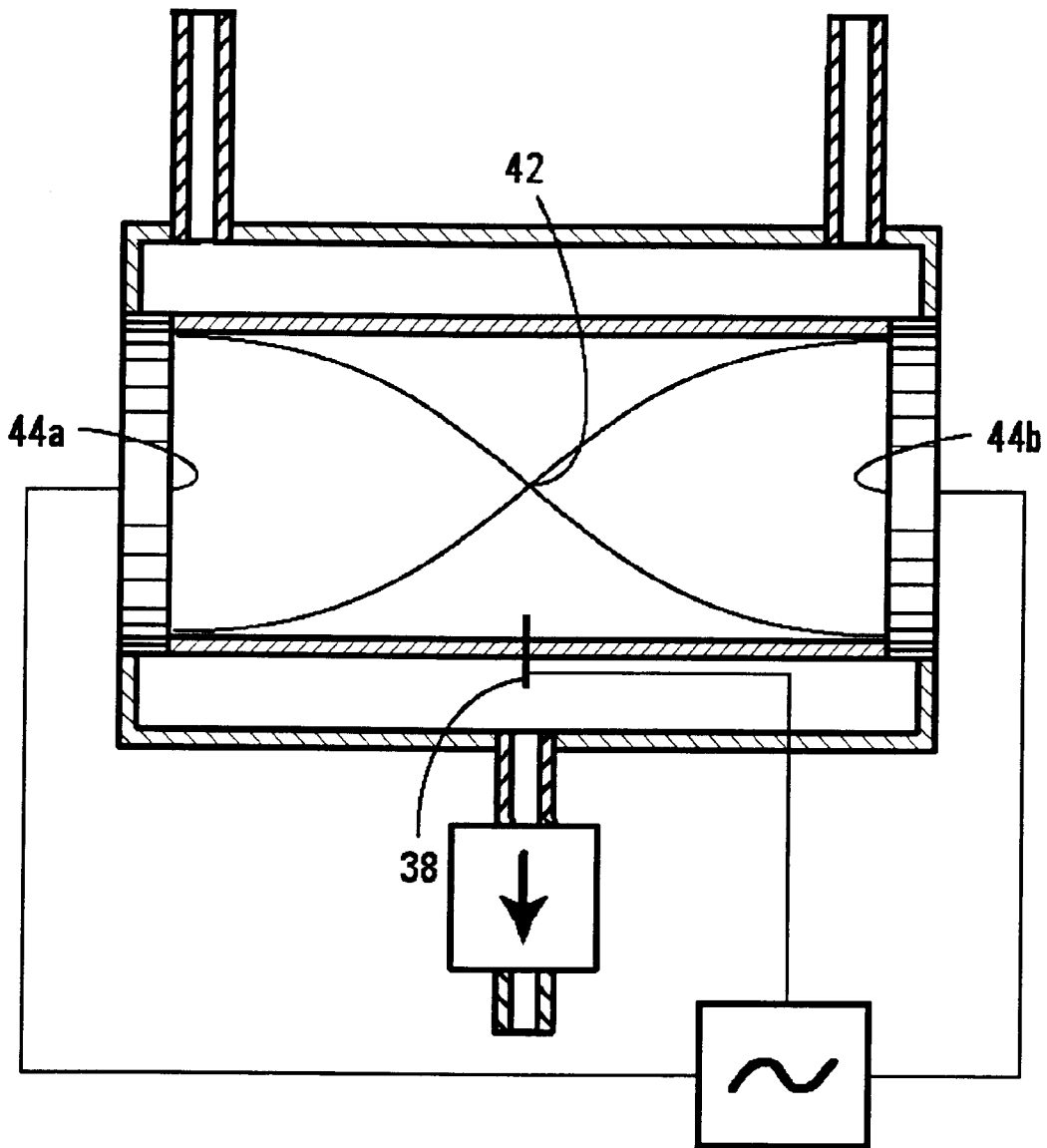

FIG. 4b

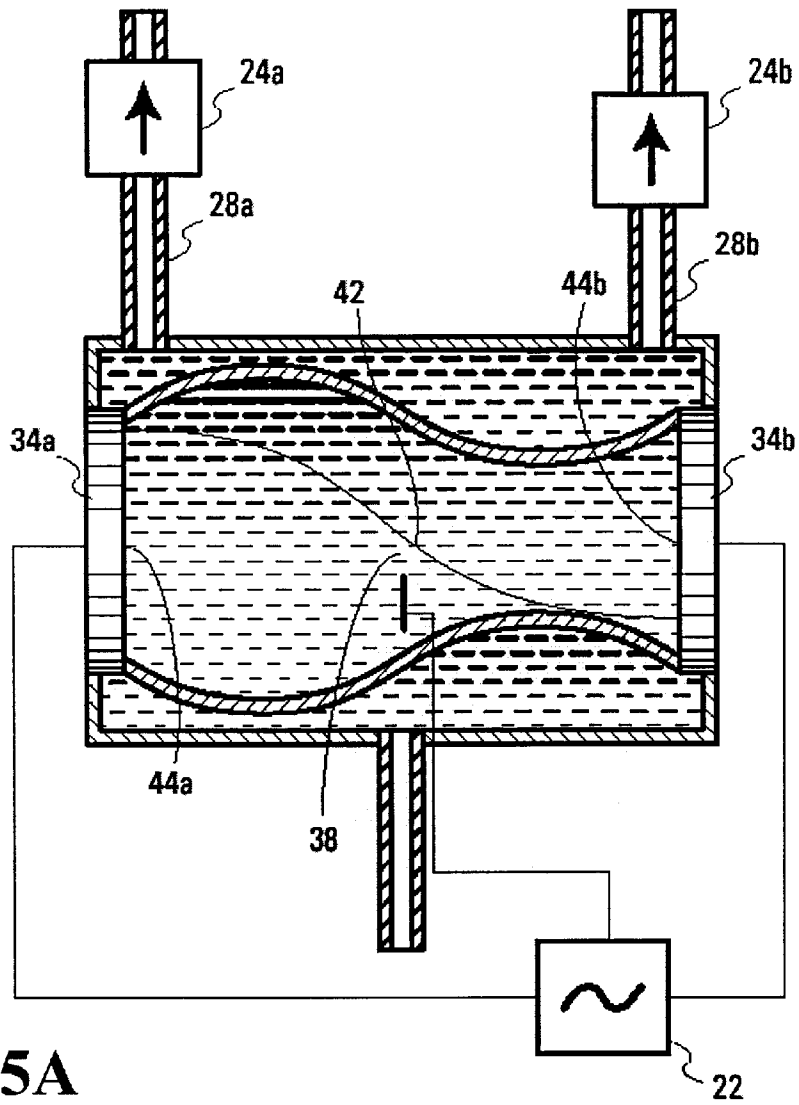

FIG. 5A

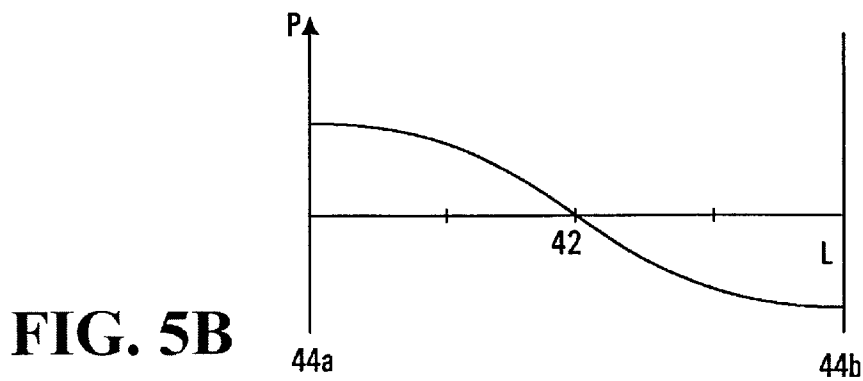

FIG. 5B

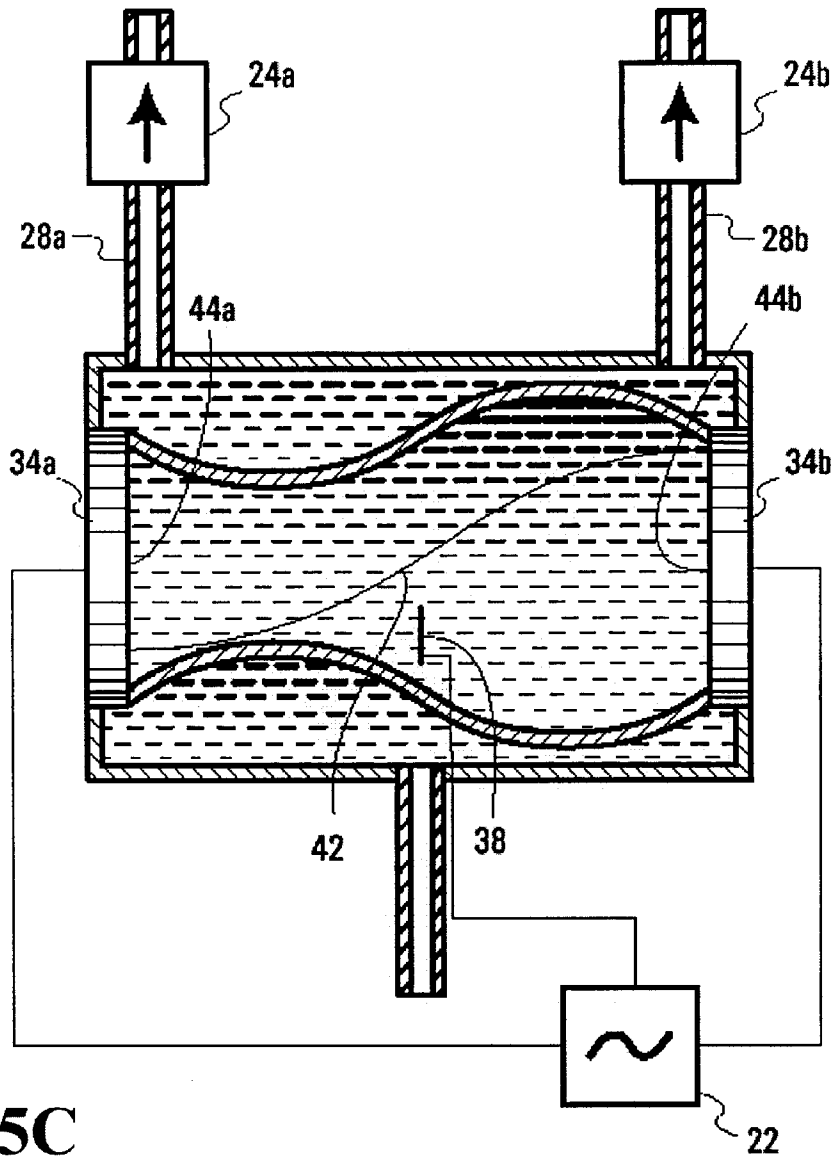

FIG. 5C

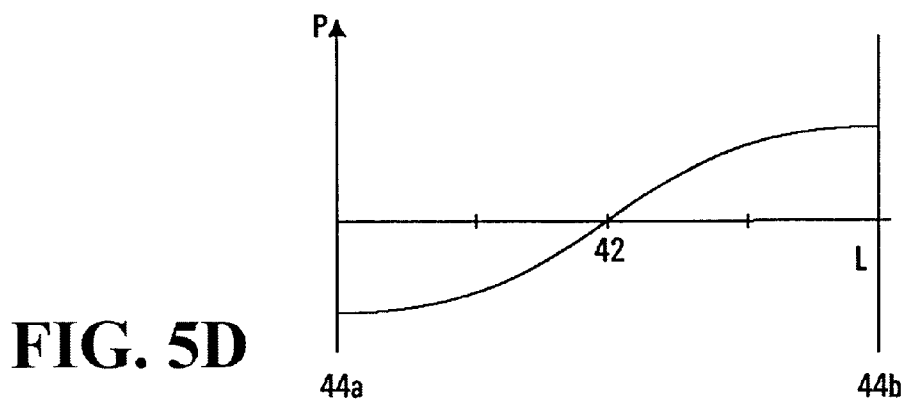

FIG. 5D

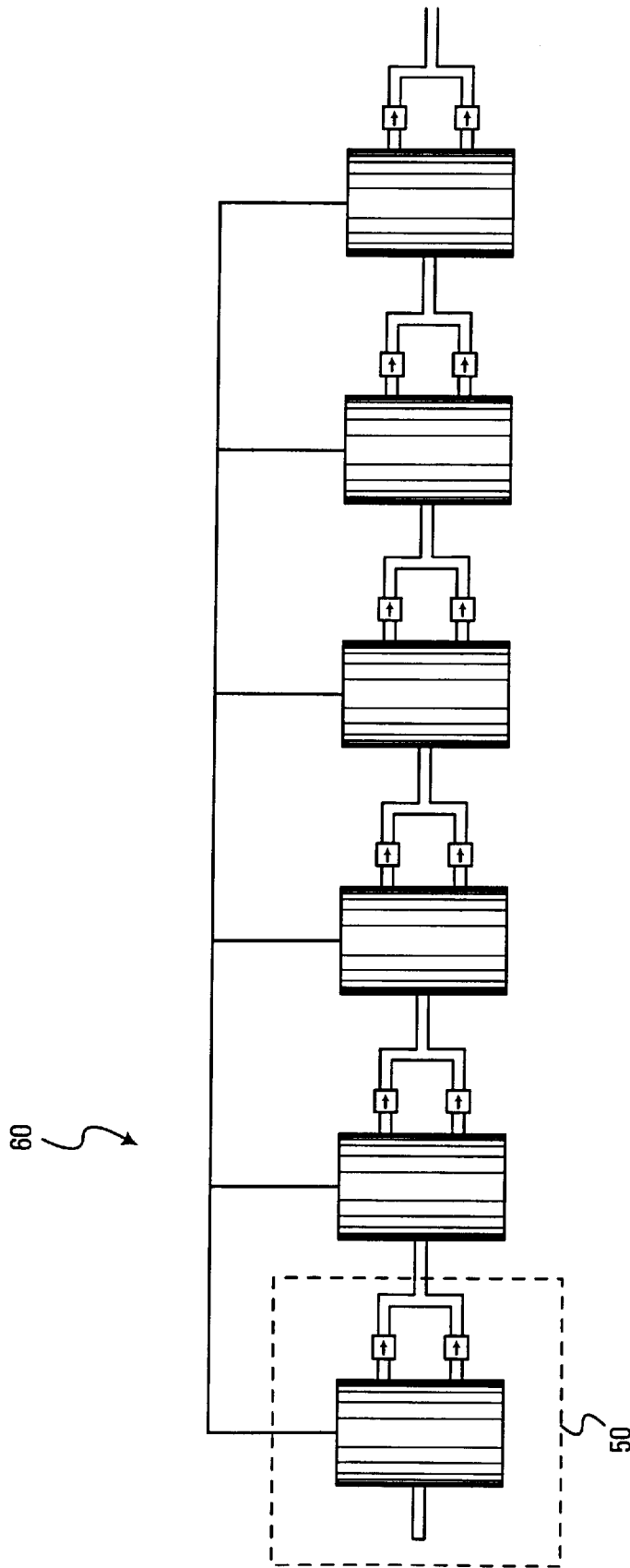

FIG. 6

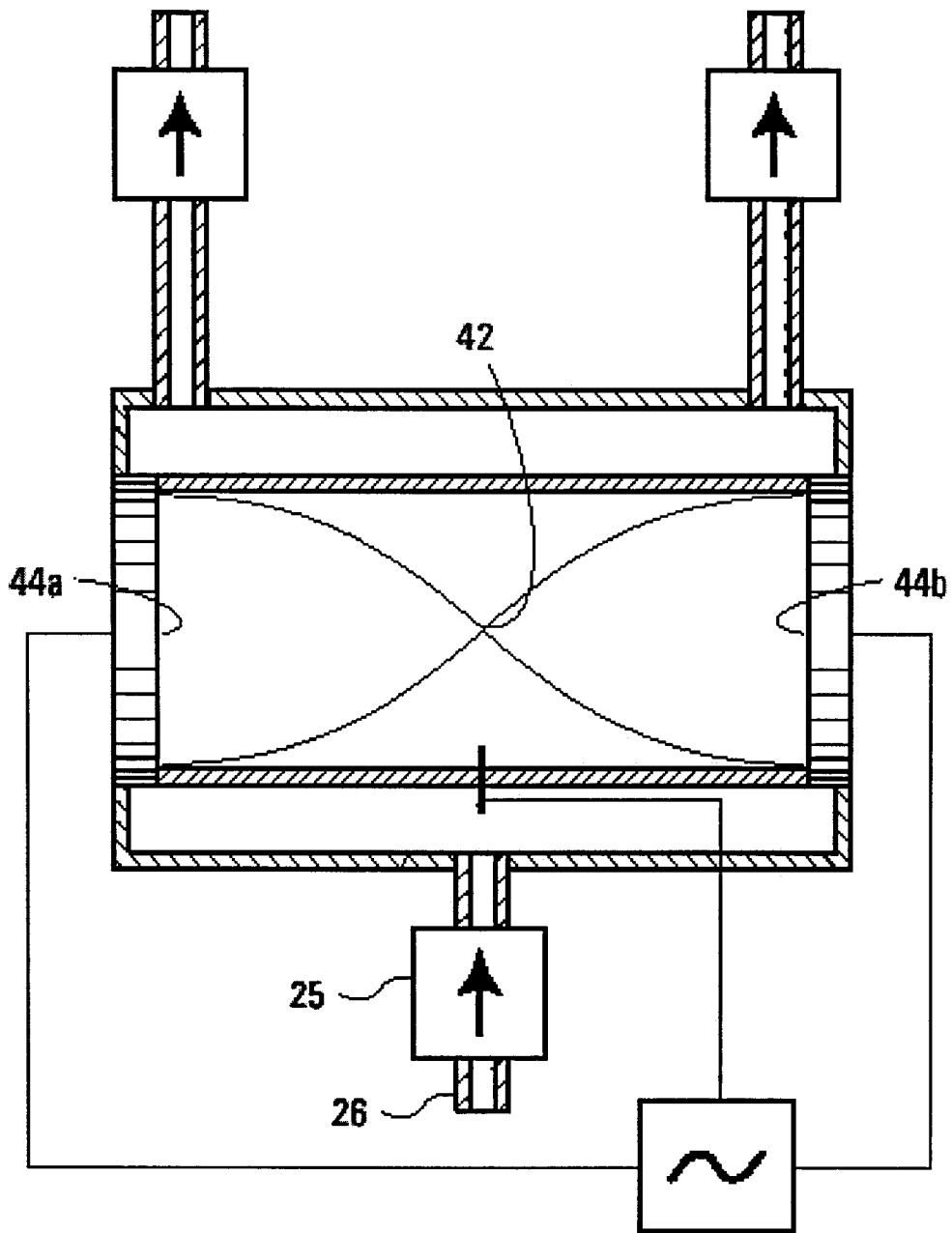

FIG. 7

STANDING WAVE EXCITATION CAVITY FLUID PUMP

FIELD OF THE INVENTION

The present invention relates to pumps and in particular to standing wave pumps.

BACKGROUND OF THE INVENTION

Pumps are used in many applications to move or compress a pumped fluid (i.e. a liquid or gas). Pumps are typically categorized as dynamic pumps or displacement pumps. Dynamic pumps add energy to a pumped fluid to increase its velocity. Displacement pumps use a volume change to displace pumped fluid in order to compress and pump the fluid. In any event, the majority of conventional pumps use moving parts. Use of moving parts lowers pump efficiency through energy losses against frictional forces. Moving parts also reduce overall pump dependability and increase cost of operation since they are subject to mechanical failure and fatigue and require maintenance. Moving parts also generally require the application of a lubricant, which needs to be replenished and which must be isolated from the pumped fluid.

In order to overcome some of the problems of conventional mechanical moving parts pumps, pumps that have fewer or no moving parts have been proposed. These pumps often pump fluids without using direct mechanical interactions with the fluid to displace or compress the fluid. With fewer moving parts, these pumps are also typically lighter than moving pumps capable of pumping fluids at the same rates and pressures. Such example pumps pressurize fluids using heat, or excite the fluids by various methods. Some pumps achieve a pumping action using the properties of standing waves, and are sometimes referred to as "Standing Wave Pumps".

In general, these standing wave pumps include a chamber defining a pump cavity. The chamber has a fluid inlet and outlet through which the pumped fluid enters and exits. An excitation source provides excitation energy to establish a standing wave in the pumped fluid in the chamber. The excitation source is matched to the pumped fluid and the length of the excitation chamber so that a travelling wave generated by the excitation source is reflected upon itself within the chamber to create the standing wave. The excitation source may be mechanical, electrical, thermal, electromagnetic or the like. The standing wave results in one or more pressure nodes and pressure anti-nodes within the chamber and the pumped fluid. Generally, the pressure at a pressure node is relatively constant at approximately the undisturbed pressure of the pumped fluid while the pressure at a pressure anti-node fluctuates above and below the undisturbed pressure of the pumped fluid. The inlet and outlet may be placed proximate the pressure nodes and anti-nodes of the chamber, respectively. Thus, fluid may be guided from the outlet through a check valve that prevents the pumped fluid from re-entering the chamber during low pressure portions of the cycle at the pressure anti-node.

In conventional standing wave pumps, the excitation source acts directly on the pumped fluid, and is matched to the speed of a travelling wave within the pumped fluid and the length of the excitation chamber. As such, a particular pump may only be suitable for pumping a single type of fluid. Even more disadvantageously, particular excitation sources may not be effective or may only be able to act on a limited class of pumped fluids. For example, electric and

magnetic excitation sources may only act on fluids having certain electric and magnetic properties. Moreover, microscopically, the action of the excitation source may be harsh and could have an adverse effect on the pumped fluid.

5 There is therefore a need for an improved pump that uses the properties of standing waves.

SUMMARY OF THE INVENTION

10 It is therefore an object of this invention to provide a pump that uses a standing wave within an excitable medium in order to pump fluids.

In accordance with the invention, a standing wave is established within a contained excitable medium. The excitable medium is allowed to exert pressure on a pumping cavity isolated from the excitable medium by a wall. The standing wave acts through the wall to exert pressure on a pumped fluid within the pumping cavity, thereby pumping the fluid through a pumping cavity from an inlet to an outlet.

20 In accordance with an aspect of the present invention a pump includes an outer body defining a pumping cavity. The outer body includes an inlet and an outlet in communication with the pumping cavity. A housing defines a driving cavity. The housing includes an outer surface at least partially contained within the pumping cavity. An excitable medium is contained in the driving cavity. An excitation source is in communication with the excitable medium to create a standing wave within the excitable medium which causes deformation of the outer surface of the housing. A pumped fluid is pumped from the inlet to the outlet through the pumping cavity by the deformation of the outer surface of the housing when the excitation source is operated.

30 In accordance with another aspect of the present invention there is provided a pump including a hollow cylindrical housing forming a driving cavity. A hollow cylindrical outer body has a larger diameter than, and is positioned co-axially with the housing forming a pumping cavity therebetween. An excitable medium is provided within the driving cavity. An excitation source creates a standing pressure wave in the excitable medium. The standing wave forms pressure nodes and pressure anti-nodes in the excitable medium. An inlet in the outer body is adjacent to the pressure node of the standing wave. An outlet in the outer body adjacent to the pressure anti-node of the standing wave. A pumped fluid is pumped from the inlet to the outlet through the pumping cavity when the excitation source is operated.

40 In accordance with yet another aspect of the present invention there is provided a method of pumping a pumped fluid including exciting an excitable medium provided in a housing to produce a standing wave therein and thereby produce deformations in the housing and providing the pumped fluid to a pumping cavity in communication with the housing such that the deformation generates volume changes in the pumping cavity. The pumped fluid is thus pumped through the pumping cavity.

55 In accordance with yet a further aspect of the present invention there is provided a pump including a housing defining a driving cavity containing an excitable medium. An outer body defines a pumping cavity. The pumping cavity at least partially contains an outer wall of the housing. An inlet and an outlet are in communication with the pumping cavity to guide a pumped fluid to and from the pumping cavity. An excitation source is in communication with the excitable medium, and operable to produce a travelling mechanical wave within the excitable medium. The excitation source, the excitable medium and the driving cavity are matched to produce a standing pressure wave

within the excitable medium as a result of the travelling mechanical wave. The outer wall of the housing deforms as a result of the standing pressure wave, and thereby exerts pressure on the pumped fluid within the pumping cavity. The pressure on the pumped fluid forces the pumped fluid from the pumping cavity through the outlet.

In accordance with an aspect of the present invention there is provided a method of pumping a pumped fluid including establishing a standing wave within a secondary fluid; allowing the secondary fluid to exert pressure on a wall in contact with the pumped fluid, to deform the wall; using deformation of the wall to pump the pumped fluid from an inlet to an outlet.

In accordance with an aspect of the present invention there is provided a pump including an outer body and a wall within the outer body. The outer body and the wall define a pumping cavity and an excitation cavity within the outer body. An excitable medium is within the excitation cavity. A pumped fluid is within the pumping cavity. An excitation source is coupled to the excitable medium. The excitation source is operable to excite the excitable medium and create a standing wave therein. The standing wave acts through the wall to pump the fluid through the pumping cavity.

Other aspects and features of the present invention will become apparent to those of ordinary skill in the art upon review of the following description of specific embodiments of the invention in conjunction with the accompanying figures.

BRIEF DESCRIPTION OF THE DRAWINGS

In the figures, which illustrate, by the way of example only, embodiments of this invention:

FIG. 1 is a schematic diagram of a pump, exemplary of an embodiment of the invention;

FIG. 2 is a schematic cross-sectional view of the pump of FIG. 1, taken along line II—II;

FIG. 3 is an end view of the pump of FIG. 1;

FIG. 4 is a schematic diagram illustrating mechanical displacement and pressure waves within the pump of FIG. 1, in operation, and FIG. 4b is a similar schematic diagram of an alternate embodiment of the pump of FIG. 1;

FIGS. 5A–5D schematically illustrate the pump of FIG. 1, in operation;

FIG. 6 is a schematic diagram of a multi-stage pump arrangement using the pump assembly of FIG. 1.

FIG. 7 is a schematic diagram similar to FIG. 4, showing another feature of the invention;

DETAILED DESCRIPTION

FIGS. 1–3 illustrate a pump 10, exemplary of an embodiment of the present invention. As illustrated, pump 10 includes a housing 12 contained at least partially within an outer body 14. Housing 12 is formed by an outer wall 30 that defines a hollow driving (or excitation) cavity 18. Outer body 14 is formed by an outer wall 32 and is similarly hollow forming a pumping cavity 16 between outer wall 32 of outer body 14 and outer wall 30 of housing 12. Outer body 14 includes an inlet 26 and outlets 28a and 28b that extend away from body 14 and away from the central axis of pump 10. Inlet 26 and outlets 28a and 28b are in fluid communication with pumping cavity 16 to allow pumping of a pumped fluid 46. Preferred positions of inlet 26 and outlets 28a and 28b along the length of pump 10 are described below.

In the illustrated embodiment, housing 12 and outer body 14 are regular cylinders, coaxial with each other, as best viewed in FIG. 2. Housing 12 has a smaller diameter than outer body 14. Preferably, housing 12 and outer body 14 are the same length.

Exemplary one way check valves 24a and 24b are in communication with the outlets 28a and 28b, respectively. These valves 24a and 24b, if required, may limit back flow of a pumped fluid 46 into pumping cavity 16. Valves 24a, 24b may be Tesla valves, Reed valves, or other suitable valves known to those of ordinary skill. Referring to FIG. 7, a one-way check valve 25 may also be provided in flow communication with the inlet to prevent back-flow out of the pumping cavity.

Housing 12 defines a driving cavity 18. An excitable medium 20 fills driving cavity 18. An excitation source 22 is provided in communication with excitable medium 20 and is coupled to excitable medium 20, so that excitation source 22 may generate corresponding displacement and pressure waves within excitable medium 20. As will become apparent, this arrangement allows excitation source 22 to act on excitable medium 20 to generate a standing pressure wave therein. Preferably, driving cavity 18 is sealed at its ends by transducers 34a and 34b. Transducers 34a and 34b form part of excitation source 22 and are used to generate travelling waves that travel along the length of driving cavity 18, between its ends. As should be appreciated, so sealed, driving cavity 18 is closed. That is, in normal operation excitable medium 20 cannot enter or exit from driving cavity 18.

Preferably, excitable medium 20 is matched or coupled to the excitation source 22, ensuring that the excitation source 22 may excite excitable medium 20. Excitable medium 20, may be a secondary fluid different from pumped fluid 46. Excitable medium 20 is preferably a liquid. Examples of suitable excitable media include water, oil, carbon fuels, or any other medium that may be excited as described herein. Excitable medium 20 is also preferably pre-pressurized within driving cavity 18 to a chosen static pressure. In this way the excitable medium 20 may be excited to fluctuate in pressure above and below this static pressure.

Outer wall 32 of the outer body 14 is formed of a relatively rigid material. Outer wall 30 of the housing 12, on the other hand, is preferably formed of a material allowing outer wall 30 to deform as excitable medium 20 is excited within driving cavity 18, and thereby transmit the effects of driving cavity 18 to pumping cavity 16. Outer wall 30 may for example be formed of metal, steel, rubber, plastic or the like, depending on the operating frequency and pressure of excitable medium 20.

As will be appreciated, housing 12 and outer body 14 may be otherwise arranged. For example, housing 12 and outer body 14 need not be cylindrical in shape. Housing 12 and outer body 14 may be toroidal or rectilinear, or of any other suitable shape appreciated by those of ordinary skill. Further, housing 12 and outer body 14 need not be the same shape or length. Similarly, housing 12 and outer body 14 need not be coaxial. A person of ordinary skill will readily appreciate other arrangements of housing 12 and outer body 14 forming an appropriate driving cavity 18 and pumping cavity 16. For example, any suitable wall may be used to divide the interior of housing 12 into driving cavity 18 and pumping cavity 16.

Pumping cavity 16 may be sealed at each of its ends by annular walls 36a and 36b, extending radially outward from transducers 34a and 34b to outer wall 32. As illustrated in

FIG. 3, annular wall **36b** and transducer **34b** when at rest, may be co-planar, thereby defining a disk-shaped end wall for pump **10**.

Excitable medium **20** and excitation source **22** are chosen and designed to produce an appropriate standing acoustic wave within driving cavity **18**. Excitation source **22** may be formed, for example as shown in FIG. 1, using two transducers **34a** and **34b** at either end of driving cavity **18**. These transducers **34a** and **34b** act as agitators and may be piezoelectric transducers, or other electromechanical transducers known to those of ordinary skill. Alternatively, excitation source **22** may include a single transducer (not shown) located at an intermediate point along the length of housing **12** so as to excite excitable medium **20**.

As an alternative, excitation source **22** could include an axially moveable end wall in place of transducers **34**, formed as part of a housing **12** having a length shorter than outer body **14**.

As a further alternative, excitation source **22** could include an electrical discharge device (not shown) placed within driving cavity **18** adapted to release an electrical spark creating a hydrostatic pressure wave of very high pressure within excitable medium **20**. Such a hydrostatic pressure wave results from the sudden extreme and localized heat release and the resulting local evaporation and re-condensation of the excitable medium **20**. As yet a further alternative, excitation source **22** may be formed of a plurality of heating elements (not shown) placed lengthwise along driving cavity **18**. A control unit (not shown) could sequentially heat such individual heating elements to provide localized heating of excitable medium **20** applied longitudinally in driving cavity **18** and thereby creating pressure differentials to generate a travelling wave within excitable medium **20**. Similarly, instead of a localized heat generator, excitable medium **20** could be electrostrictive or magnetostrictive, and a corresponding source of magnetic flux or an electric field could be arranged to generate a lengthwise travelling magnetic or electric wave that acts on excitable medium **20** to create a corresponding acoustic wave. Yet another excitation source could include a localized heat source, such as a laser diode, resistance heater or the like. Oscillations within the excitable medium **20** could be produced by causing a liquid forming excitable medium to rapidly change phase, between liquid and vapor. Direct or alternating current could drive such a heat source. Other alternative excitation sources **22** are described in, for example, U.S. Pat. No. 5,020,977 to Lucas, the contents of which are hereby incorporated by reference, or will be known to one of skill in the art.

Optionally, a pressure sensor **38** is communication with excitation source **22**. As detailed below, measurements of pressure sensed at sensor **38** may control the frequency of operation of excitation source **22**. Pressure sensor **38** may be a conventional pressure transducer providing an electric signal in proportion to measured pressure.

Further excitation source **22** may include a controller (not specifically illustrated) operable to control the frequency of operation of excitation source **22**, and thereby the frequency of excitations within driving cavity **18**. This controller may, for example, be a proportional-integral-differential ("PID") controller configured to respond to sensed measurements, as provided by pressure sensor **38**.

The length of housing **12** is designed in co-ordination with the excitable medium **20** and the excitation source **22** so that excitation of excitable medium **20** may produce a standing wave **24** within driving cavity **18**. Preferably, the

length of housing **12** and excitation source **22** are matched so that the length of housing **12** equals a half wavelength ($\lambda/2$) (where $\lambda=c/f$) of a travelling wave in excitable medium **20**. The net characteristic acoustic velocity (c) within excitable medium **20** is the speed of sound within excitable medium **20**. Of course, the length of the cavity could be chosen to be an odd integer multiple of one half the wavelength (i.e. $n\lambda/2$ where n is an odd integer).

In operation, excitation source **22** generates a travelling acoustic wave having a wavelength λ within excitable medium **20** within driving cavity **18**. In the embodiment of FIG. 1, a longitudinal travelling wave is generated by the synchronized oscillations of transducers **34a** and **34b**. As noted, a similar travelling wave could be formed in excitable medium **20** in any number of known ways. As will be appreciated, the travelling wave may propagate in directions that are not longitudinal. In any event, when this travelling wave is incident on a transducer **34b** or **34a** it is reflected and travels distance $\lambda/2$ to arrive in-phase at transducer **34a** or **34b**. As described above, the length of housing **12** and frequency of excitation source **22** thus cause driving cavity **18** to act as a resonant cavity. A standing acoustic wave **48** (see FIG. 4) is, in turn, established within excitable medium **20**. As will be appreciated, the acoustic wave **48** manifests itself in alternating regions of high and low pressure along the length of driving cavity **18**. It is further characterized by nodes and anti-nodes. Pressure at each point along the length of cavity varies cyclically from in time. At the nodes, the pressure remains constant at the undisturbed pressure of the excitable medium. The ongoing reflection of travelling acoustic waves at transducers **34** results in an ongoing reinforcement and resulting resonance.

Notably, the net characteristic velocity (c) within driving cavity **18** depends on the physical characteristics of excitable medium **20**, as well as the characteristics of wall **30**, and the contents of pumping cavity **16** and its effective bulk modulus. In effect, the net mechanical load on which excitation source acts is the combined load of the excitable medium **20**, and pumped fluid **46**, acting through wall **30**. The speed of an acoustic wave in medium **20**, is in turn a function of this mechanical load. For particular chosen combinations of excitation medium, and pumped fluid this net load, and net acoustic velocity is quite predictable.

For greater flexibility, optional sensor **38** may provide a control signal to ensure that driving cavity **18** is driven at an appropriate frequency, so that a standing wave is produced within driving cavity **18**. Conveniently, this sensor may be placed along an axial position along the length of cavity **18**, corresponding to the location of a node (as illustrated) or anti-node within the cavity **18**. The optional controller may thus adjust the frequency of the excitation source **22** to ensure nodes (or anti-nodes) at the location of sensor **38**. This, in turn, ensures that driving cavity **18** is resonant. Oscillations within driving cavity **18** may thus be tuned in a manner analogous to the tuning of a laser tube.

As shown in FIG. 4 the standing pressure wave **40** so produced in the excitable medium **20** has pressure anti-nodes **44a**, and **44b** laterally proximate transducers **34a** and **34b** of housing **12** and a pressure node **42** midway along the length of housing **12**. The instantaneous pressure at pressure anti-nodes **44a** and **44b** fluctuates above and below the undisturbed pressure (i.e. pre-pressurized static pressure) of excitable medium **20** while the instantaneous pressure at pressure nodes **42** remains relatively constant at the undisturbed pressure of the excitable medium **20**. Thus, a fluctuating pressure differential is created between pressure node **42** and pressure anti-nodes **44**. In particular, the

pressure fluctuations at pressure anti-nodes **44a** and **44b** are of opposite phase.

Now, since pressure within excitable medium **20** acts in all direction, outer wall **30** expands or contracts radially in accordance with fluctuations in the pressure wave **40**. This is illustrated more particularly in FIGS. **5A** and **5D**. Specifically, FIGS. **5A** and **5B** illustrate pump **10**, in operation at a time **t0**. As illustrated, at this time **t0**, the amplitude of the standing pressure wave **40** is at its maximum at anti-node **44a**, proximate transducer **34a**. FIGS. **5C** and **5D** illustrates pump **10** at a time **t1** one half-period (or $1/(2f)$) later. At this time **t1**, the amplitude of the standing pressure wave **40** is at its minimum at anti-node **44a**. As noted, pressure within driving cavity **18** exerts a force on outer wall **30**. This, in turn causes localized expansion and contraction of the outer wall **30** along its length, in a direction transverse to the direction of travel of the pressure waves within excitable medium **20**. This is again illustrated in FIGS. **5A** through **5D**. The expansion and contraction illustrated in FIGS. **5A** through **5D** are exaggerated for purposes of illustration. As illustrated, as one half of housing **12** expands, its opposite half contracts, while the mid-point, proximate pressure node **42a** does not expand or contract. This occurs at the resonant frequency of the system coupled to the excitation source.

Expanding and contracting outer wall **30**, in turn, exerts a radial outward force and pressure on pumped fluid **46** within pumping cavity **16**. The outer wall **30** obeys Hooke's law. However, pumped fluid within pumping cavity **16** acts on outer wall. As will be appreciated, pressure fluctuations within pumping cavity **16** are governed by the expansion and contraction of outer wall **30** and the distance between outer wall **30** and outer wall **32**. As should now be appreciated, and as noted above, the resonant frequency within pumping cavity **16** will depend on the excitable medium **20**, the stiffness of wall **30**, and the effect of the fluid within pumping cavity **16** on this wall. That is, the resonant frequency within cavity **16** depends on the compound impedance of the net mechanical system being excited. Conveniently, however, excitation source **22** only acts directly on excitation medium **20**.

As noted, sensor **38** in communication with controller of source **22** may allow the excitation source **22** to excite excitation medium **20** within cavity **18** to resonance for a wide variety of pumped fluids.

As should now be apparent, pressure sensor **38** could be replaced with a displacement sensor in the form of a strain gauge or the like, and located on the surface body **30** proximate a node. Resonance within cavity **18** could be controlled by using signals from sensor **38**.

Now, pumped fluid **46** is guided into pumping cavity **16** by way of inlet **26**. The resulting pressure gradient within pumped fluid **46** in cavity **16** along its length is also illustrated in FIGS. **5A** and **5B**. As illustrated, pressure within pumped fluid **46** varies least proximate node **42** and most significantly near anti-nodes **44a** and **44b**. Conveniently, inlet **26** and outlets **28** are located in lateral proximity to these pressure nodes **42** and anti-nodes **44**, respectively. As such, as shown in the example embodiment of FIG. **1**, inlet **26** may be laterally located midway between the transducers **34** of housing **12** proximate the pressure node **42a**. Outlets **28** may be proximate the ends of wall **30** and proximate pressure anti-nodes **44a** and **44b**. Additionally one way check valves **24a** and **24b** ensure that pumped fluid **46** forced from pumping cavity **16** does not re-enter pumping cavity **16** as the pressure proximate an associated

outlet **28** diminishes. Conveniently, sensor **38** may be located laterally proximate node **42a** and inlet **26**.

Now, pumped fluid **46** is guided into pumping cavity **16** by way of inlet **26**. The resulting pressure gradient within pumped fluid **46** in cavity **16** along its length is also illustrated in FIGS. **5A** through **5D**. As illustrated, pressure within pumped fluid **46** varies least proximate node **42** and most significantly near anti-nodes **44a** and **44b**. Conveniently, inlet **26** and outlets **28** are located in lateral proximity to these pressure nodes **42** and anti-nodes **44**, respectively. As such, as shown in the example embodiment of FIG. **1**, inlet **26** may be laterally located midway between the transducers **34** of housing **12** proximate the pressure node **42a**. Outlets **28** may be proximate the ends of wall **30** and proximate pressure anti-nodes **44a** and **44b**. Additionally one way check valves **24a** and **24b** ensure that pumped fluid **46** forced from pumping cavity **16** does not re-enter pumping cavity **16** as the pressure proximate an associated outlet **28** diminishes. Conveniently, sensor **38** may be located laterally proximate node **42a** and inlet **26**.

As indicated above, since the pressure in driving cavity **18** at the pressure anti-nodes **44a** and **44b** oscillate above and below the undisturbed pressure of the excitable medium **20**, similar pressure fluctuations occur in pumping cavity **16** due to the deformation of outer wall **30** and the rigidity of the outer wall **32**. Since the pressure fluctuations are of opposite phase at each of the pressure anti-nodes **44a** and **44b** of pumping cavity **16** (i.e. proximate each of the outlets **28**), the outlets **28a** and **28b** provide a differential output pumping flow: one outlet **28a** pumps while the other outlet **28b** does not and vice versa. Conveniently, outputs of valves **24a** and **24b**, downstream of outlets **28a** and **28b** may be joined to provide moderately constant steady state flow from pump **10**. Alternatively, inlet and outlet valves **24** and **28** and could be laterally co-located along the length of pumping cavity **16**. In this way, pump **10** could optionally be divided into two pumping chambers, one at each end. The two chambers could be isolated by a suitable membrane. Referring to FIG. **4b**, in an alternate embodiment, the inlet(s) could be located also be at an anti-node, and the outlet(s) could be located at a node.

Generally, pressure fluctuations within both driving cavity **18** and within pumping cavity **16** are symmetrical about the undisturbed pressure of excitable medium **20** and pumped fluid **46**, respectively. As the pressure within cavity **18** and pumping cavity **16** remains positive, pressure fluctuations may have peak values-to-peak values of two times the undisturbed pressure in each of cavity **16** and **18**. However, as described below, a number of pump stages may be combined to obtain as large a pressure ratio as is desired.

As should now be appreciated, excitable medium **20** may be excited anywhere along its length (other than at a node) in order to establish a suitable travelling wave, and thus establish a standing pressure wave, as illustrated. Conveniently, the location of any excitation source **22** that excites excitable medium **20** will affect the magnitude of the pressure differential between nodes and anti-nodes. That is, the pressure differential can be adjusted, by locating excitation source **22** input at a location towards the midpoint of housing **12**. The nearer the excitation source **22** acts to a node, the less the excitation source need vary the pressure of the excitable medium **20**, while still establishing a standing wave, as illustrated. A pressure amplification of the alternating pressure of excitation source **20** (within the driving cavity **18**) can be obtained, thus allowing for proper matching between the driving cavity **18** operating pressure and the available alternating pressure value.

As should now also be appreciated, annular wall **36** need not be annular, or co-planar with transducer **34**. Pumping cavity **16** could be sealed with rigid end-walls separate from or forming part of, end walls (not shown) sealing driving cavity **18**. In this case, excitation source **22** could be located within driving cavity **18** and could use rigid end walls (not shown) to establish a standing wave. Moreover, excitation source **22** need not generate the standing wave pattern depicted in FIGS. **4**, **5A** through **5D**. Many suitable variations of standing wave patterns, including an arbitrary number of nodes and anti-nodes may be similarly used in order to pump liquid in a pump similar to pump **10**. Pressure nodes need not be formed at the ends of housing **12**. Instead, end walls of housing **12** could be rigid and pressure anti-nodes may be formed at these end walls. Similarly, driving cavity **18** and arrangement of excitation source **22** need not generate a standing wave that is symmetric about the length of driving cavity **18**. Instead, a single transducer or other agitator may be located within driving cavity **18**. Of course, inlets and outlets may need to be appropriately located proximate pressure nodes and anti-nodes in such alternate standing wave patterns. As well, housing **12** need not be entirely contained within outer body **14**. Instead, only a portion of outer wall **32** need extend within a pumping cavity formed between outer wall **32** of outer body **14** and outer wall **30** of housing **12**.

Advantageously, excitation source **22** does not act directly on pumped fluid **46** allowing pump **10** to pump a larger variety of pumped media. Further, excitable medium **20** and excitation source **22** can be freely chosen to provide an efficient pumping action without regard to the pumped fluid **46**. For example, when excitation source **22** includes an electrical discharge device, the excitable medium **20** must support the electrical discharge phenomenon and preferably, in a way that does not deteriorate the excitable medium **20** significantly. In this case, examples of excitable media include water, fuel, oil, or the like.

FIG. **6** schematically illustrates a multi-stage pump **60** that uses a plurality of single-stage pumps **50** each identical to exemplary pump **10** of FIG. **1**. The plurality of single stage pumps **50** are arranged in series so that the pressurized output of one single stage pump **50** is fed to the input of an adjacent downstream pump **50** in order to further pressurize fluid pressurized by a previous single stage pump **50**. Excitation sources (identical to source **22** of FIG. **1**) for each single stage pump **50** are not shown in FIG. **6**. In the multi-stage pump **60**, these excitation sources may preferably be coupled to operate in phase. Alternatively, a single common excitation source (not shown) may be used to drive each of the single stage pumps **50**. As with pump **10**, the total flow rate of the multi-stage pump **60** is controlled by the magnitude and frequency of the excitation source. Advantageously, each of the multi-stage pumps partially pressurized the pumped liquid. The pumping cavity of each of the single-stage pump **50** need only be pre-pressurized to the contribution of that stage. Conveniently, multi-stage pump **60** could be constructed using micro-machining techniques to provide an integrated multi-staged pump **60** in a single compact package, in a manner readily understood by those of ordinary skill. One possible use of such a multi-stage pump **60** may be in, and as an integral part of, a fuel nozzle (not shown) of an engine (not shown).

A pump **10** or multi-stage pump **60** as described in the embodiments above is intended for use in fuel delivery, possibly as individual fuel nozzles or pumps and may also be usable for fuel and oil pressurization. Pump **10** can be usable with virtually any fluid such as oils, refrigerants, fuels

etc. The pump may also be useful for underwater propulsion devices and possibly also for gas pumping or compressing applications.

As should be appreciated pump **10** or multi-stage pump **60** as described in the embodiments above could be effective for pumping virtually any fluid, even fluids containing suspended solids of relatively large sizes, since there are few moving parts to come into contact with the suspended solids and result in mechanical failure and also since there is no need to directly excite the pumped fluid.

It will be further understood that the invention is not limited to the embodiments described herein which are merely illustrative of preferred embodiments of carrying out the invention, and which are susceptible to modification of form, arrangement of parts, steps, details and order of operation. The invention, rather, is intended to encompass all such modification within its scope, as defined by the claims.

What is claimed is:

1. A pump comprising:

an outer body defining a pumping cavity, said outer body comprising an inlet and an outlet in communication with said pumping cavity; and

a housing defining a driving cavity, said housing comprising an outer surface at least partially contained within said pumping cavity;

an excitable medium contained in said driving cavity;

an excitation source in communication with said excitable medium to create a standing wave within said excitable medium which causes deformation of said outer surface of said housing, such that a pumped fluid is pumped from said inlet to said outlet through said pumping cavity by said deformation of said outer surface of said housing when said excitation source is operated.

2. The pump of claim **1**, wherein said excitation source comprises a transducer in said driving cavity and in contact with said excitable medium.

3. The pump of claim **1**, wherein said excitation source produces an electrical discharge within said excitable medium.

4. The pump of claim **1**, wherein said excitation source produces heat within said excitable medium.

5. The pump of claim **1**, wherein said outer body and said housing are cylindrical and co-axial.

6. The pump of claim **1**, wherein said inlet is adjacent to a pressure node of said standing wave.

7. The pump of claim **1**, wherein said excitable medium is pre-pressurized to a static pressure greater than one-half the pressure created by said excitation source in said excitable medium.

8. The pump of claim **1**, further comprising a one-way check valve in flow communication with said outlet to prevent back-flow into said pumping cavity.

9. The pump of claim **1**, further comprising a one-way check valve in flow communication with said inlet to prevent back-flow out of said pumping cavity.

10. The pump of claim **1**, further comprising a sensor in communication within said driving cavity, and in communication with said excitation source to control a frequency of operation of said excitation source to establish said standing wave within said excitable medium.

11. The pump of claim **10**, wherein said sensor comprises one of a displacement sensor and a pressure sensor.

12. A multi-stage pump comprising:

a plurality of pumps according to claim **8**, arranged in series, wherein excitation sources of said plurality of pumps are synchronized.

11

13. A pump comprising:
 a hollow cylindrical housing forming a driving cavity;
 a hollow cylindrical outer body having a larger diameter
 than, and positioned co-axially with, said housing and
 forming a pumping cavity therebetween;
 an excitable medium provided within said driving cavity;
 an excitation source for creating a standing pressure wave
 in said excitable medium, said standing wave forming
 pressure nodes and pressure anti-nodes in said excitable
 medium;
 an inlet in said outer body adjacent to said pressure node
 of said standing wave; and
 an outlet in said outer body adjacent to said pressure
 anti-node of said standing wave,
 wherein a pumped fluid is pumped from said inlet to said
 outlet through said pumping cavity when said excita-
 tion source is operated.

14. A pump comprising:
 a housing defining a driving cavity containing an excit-
 able medium;
 an outer body, defining a pumping cavity, said pumping
 cavity at least partially containing an outer wall of said
 housing;
 an inlet and an outlet in communication with said pump-
 ing cavity to guide a pumped fluid to and from said
 pumping cavity;
 an excitation source in communication with said excitable
 medium, and operable to produce a travelling mechan-
 ical wave within said excitable medium;
 said excitation source, said excitable medium and said
 driving cavity matched to produce a standing pressure
 wave within said excitable medium, as a result of said
 travelling mechanical wave;
 said outer wall of said housing deforming as a result of
 said standing pressure wave, and thereby exerting pres-
 sure on said pumped fluid within said pumping cavity;
 said pressure on said pumped fluid forcing said pumped
 fluid from said pumping cavity through said outlet.

15. The pump of claim 14, wherein said outer body is
 cylindrical.

16. The pump of claim 15, wherein said housing is
 cylindrical, contained within said outer body, and co-axial
 therewith.

12

17. The pump of claim 16, wherein said driving cavity has
 a length equal to an integer multiple of a half wavelength of
 said mechanical wave within said excitable medium.

18. The pump of claim 17, wherein said inlet is located at
 a location along a length of said housing proximate a node
 of said standing pressure wave.

19. The pump of claim 18, wherein said outlet is located
 at a location along a length of said housing proximate an
 anti-node of said standing pressure wave.

20. The pump of claim 17, wherein said excitation source
 comprises a transducer at an end of said housing.

21. The pump of claim 17, wherein said excitable medium
 comprises one of water, oil, and carbon fuels.

22. The pump of claim 17, wherein said excitation source
 comprises an electric discharge generator which discharges
 electricity within said excitable medium.

23. The pump of claim 14, further comprising a one-way
 check valve in flow communication with said outlet to
 prevent back flow of said pumped fluid into said pumping
 cavity.

24. A multi-stage pump comprising:
 a plurality of pumps as claimed in claim 15, arranged in
 series, wherein excitation sources of said plurality
 pumps are synchronized.

25. The pump of claim 17, wherein said inlet is located at
 a location along a length of said housing proximate an
 anti-node of said standing pressure wave.

26. The pump of claim 25, wherein said outlet is located
 at a location along a length of said housing proximate a node
 of said standing pressure wave.

27. A pump comprising:
 an outer body;
 a wall within said outer body;
 said outer body and said wall defining a pumping cavity
 and an excitation cavity within said outer body;
 an excitable medium within said excitation cavity;
 a pumped fluid within said pumping cavity;
 an excitation source coupled to said excitable medium;
 said excitation source, operable to excite said excitable
 medium and create a standing wave therein;
 said standing wave acting through said wall to pump said
 fluid through said pumping cavity.

* * * * *